



# EUROCAVE

## PROFESSIONAL

# WB 8.0

Range	Wine Bar
Function	2 serving temperature <i>Service</i>
Capacity*	8 preserved bottles + 6 storage bottles

### GENERAL FEATURES

**Overall size** 602 x 1076 x 460 mm (HxWxD)  
**Weight** 85 kg  
**Cooling agent** R134a

**Warranty**

**2 years**

### PRODUCT CHARACTERISTICS

#### FUNCTIONALITIES

- **Electronic regulation from 6 to 18°C/ 43-64°F**
  - 6°-15°C/43-59°F for white wines
  - 12-18°C/54-64°F for red wines
- **Interior display**
- Both temperature settings from the right compartment
- Red or with wine whatever the compartment

#### COLD TECHNOLOGY AND INSULATION

Production of cold air	Ventilated cold air Compressor
Production of warm air	Heater
Heat activation	Automatic
Leads	CE/US/UK/JA/C6/ CH/CN/AU
Type of walls	ABS
Type of external covering	Black metal
Type of insulation	Polystyrene foam with UV protection
Type of glass	

### FITTINGS & ACCESSORIES

- **2 full glass doors, with double safety lock**
- Interior **lighting with multicolour LED (remote control)**
- **Frequency detector**
- 2 adjustable feet
- Thermal insulation and U.V. protection.
- Individual wine preservation (**new system**)
- **Air extraction** fault warning indicators
- **Excess condensation water** collected in 2 drawers
- **Black tempered glass top**



### ENERGY CONSUMPTION & PERFORMANCE

Consumption per 24hrs** (KWh)	1
Ambient temperature operating limit	10 to 35°C (50-95°F)
Electrical power (at 20°C)	100 W

WINE { BAR 8.0



<http://eurocavepro.com/>

\* Traditional Bordeaux bottles  
 \*\* with an ambient temperature of 25°C

**Flush-fitting diagram**

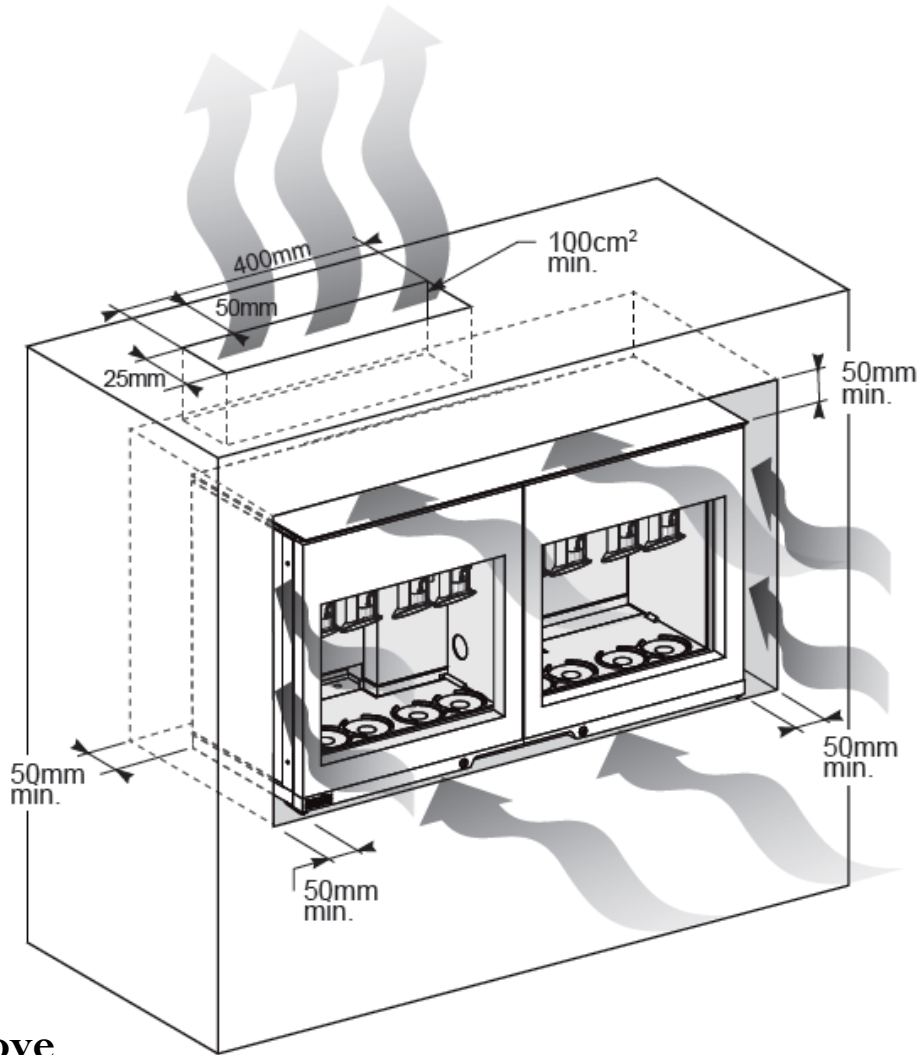

**View from above**

